

DATA SHEET

S4LFT0763/328

F-Theta
compact - fused silica
1030 - 1090 nm



outline drawing

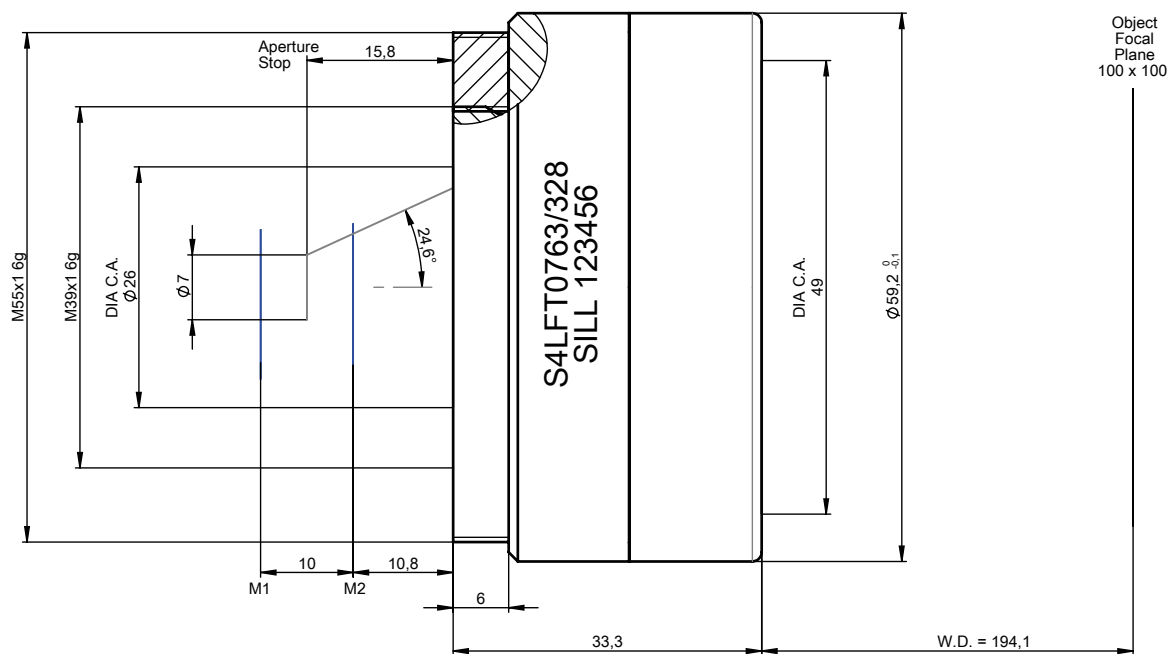

DATA SHEET

specifications

article number	S4LFT0763/328
design wavelength [nm]	1064
effective focal length [mm]	163.0
working distance [mm]	194.1
max. entrance beam-Ø [mm]	7.0
aperture stop distance [mm]	15.8
scan area for a 2 mirror system with mirror distance from lens housing for mirror 2 / mirror 1 [mm x mm]	100 x 100 10.8 / 15.8
max. telecentricity error [°]	14.6
total transmission [%]	> 97
absorption [ppm]	50
lens material	fused silica
LIDT (coating)	5.0 J/cm ² per 1ns pulse at 50Hz
SP and USP usable	yes
weight [kg]	0.17
cover glass	S4LPG3105/328
cleanliness	not specified

spot

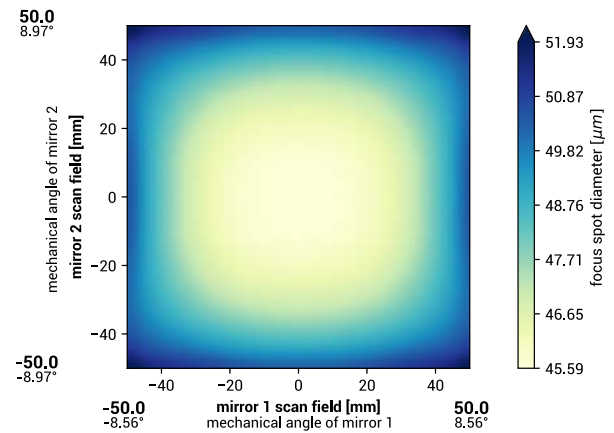

spot diameter at 86.5 % level for a Gaussian beam ($M^2 = 1$) with 7.0 mm diameter at $1/e^2$, clipped at 7.0 mm field size and mirror distances as given above for a two mirror scan system

back reflection positions

back reflections [mm] for 1064	
4.08	
47.37	
47.73	
0.00	
0.00	
0.00	
0.00	
0.00	
0.00	
0.00	
0.00	
0.00	

remarks

The stated values are based on a vignetting of less than 1 %.

Effective focal length and working distance have a tolerance of +/- 1.5 %.

Absorption tolerance +/- 25 %. Absorption may increase. Correct cleaning establishes original condition.